

Great Lakes Trade Exposition Rules and Regulations

Definition of an Exhibitor

- The GLTE is the marketplace for suppliers and original equipment manufacturers of products, software, goods and services intended for use by Green industry professionals in every aspect of design, build and maintenance of outdoor and indoor green space, turf and plant care. It is not the intention of the GLTE that consumer goods, homeowner products, or other items unrelated to the professional Green industry be on display, regardless of their method of distribution to the final consumer.

Terms of Space

- The balance due on your booth space(s) was to be paid in full by *September 30, 2009*. For all unpaid balances the deposit will be returned to the exhibitor and the space will be made available to others.

Cancellation of Contract

- A cancellation charge of 25 percent of the booth fee will be assessed if written cancellation occurs after *September 30, 2009* and before *December 1, 2009*.
- A cancellation charge of 50 percent of the booth fee will be assessed if written cancellation occurs after *December 1, 2009*.
- Cancellations made within seven days prior to the move-in date or no-shows will not receive a refund.

Tickets and Badges

- Admission to the exhibit area will be regulated by badges furnished by the management to exhibitors and their personnel.
TO RECEIVE NAME BADGES YOU MUST REGISTER by filling out the *Exhibitor Registration Form* for all of your personnel staffing your exhibit booth and return to MNLA for name badges (See “**Section 4**” of this manual).

Booth Furniture and Accessories

- Orders for additional booth furniture, floor coverings, special signs, extra lighting and other accessories should be sent to Art Craft Display, Inc. by December 21, 2009 to receive advanced prices.
- Ordering information and forms are included in this manual (see the “**Section 2**” of this manual).
- Art Craft’s address and phone number are: 3140 Three Mile Rd. NW, Grand Rapids, Michigan 49544• 1-800-292-2033.

Booth Information

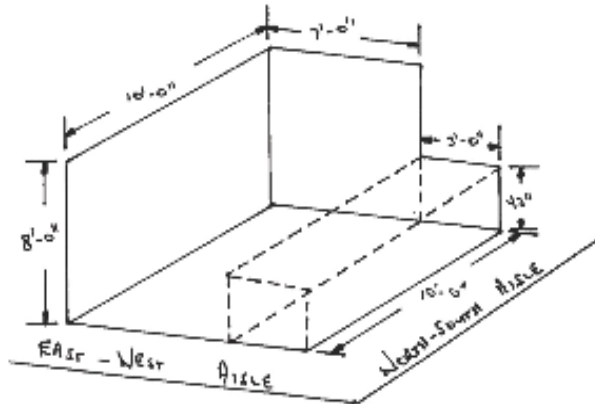

Single End Cap Booth

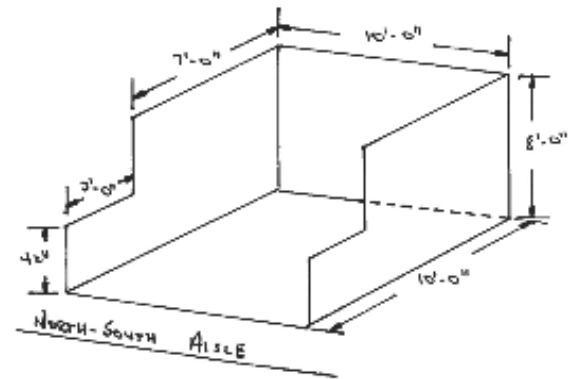

Regular Booth

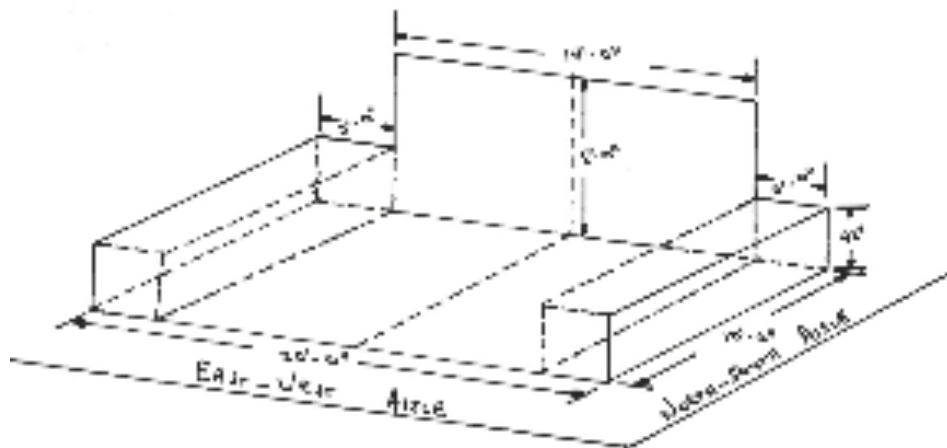

Double End Cap Booth

- Single End Cap Booth Space:
 - Your booth space cannot exceed 42" in height for the first 3' from the main aisle that runs from the south to the north.
 - There are no height restrictions in the remaining booth space.
- Regular Booth Space:
 - Your booth space cannot exceed 42" in height for the first 3' from the main aisle that runs from the south to the north.
 - There are no height restrictions in the remaining booth space.
- Double End Cap:
 - Your booth space cannot exceed 42" in height for the first 3' from the main aisles that run from the south to the north.
 - There are no height restrictions in the remaining booth space.

Booth Information cont...

- No exhibitor shall be set in place so as to obstruct the general view of others or the flow of traffic in the aisle.
- Per the Fire Marshall all equipment must have gas tank taped close and battery disconnected.
- Signs will be prepared at the expense of the exposition and will not exceed 7 inches by 44 inches in size.
- Exposed rough work on side of exhibits shall be properly covered.
- An undraped 8-foot table and two chairs, backdrops, side rails and booth sign will be provided with each exhibit space. If you do not want your table and chair, you can deduct \$27 from the price of each purchased space.
- Only the aisles in the hall will be carpeted, so plan accordingly for your comfort.
- A forklift will be available for move-in and move-out, compliments of the sponsoring organizations.
- No nails, screws or bracing wires may be used without the consent of the exhibit manager.
- All property destroyed or damaged by exhibitors must be replaced in its original condition by the exhibitor or at his/her expense.

Storage

- Each exhibitor is responsible for the transportation, storage and assemblage of his/her display material, which may be readied and set in place the day of move-in as soon as backdrops and side rails are set in place to receive materials.
- Art Craft Display, Inc. offers storage of exhibit-related material during the exposition. Arrangements for storage can be made at the Art Craft Display Service Desk during Exhibitor move-in.

Security

- The exhibit hall will be locked the nights of January 4 and 5. Any late-hour entrance to the hall must be approved by the exposition manager.
- The exhibitor's property is shown at his/her own risk and neither the hotel, the Exhibition Center, nor the Michigan Nursery and Landscape Association, nor Michigan Turfgrass Foundation shall assume responsibility therefore.
- The exhibitor assumes the responsibility and liability for losses, damages and claims arising out of injury or damage to exhibitors' display equipment and other property brought upon the premises of the hotel and shall indemnify and hold harmless the Michigan Nursery and Landscape Association, Michigan Turfgrass Foundation, and the hotel, Exhibition Center, agents, servants and employees from any and all such losses, damages and claims.